

LDY-C/X



Application range

LDY-XC series control signal lightning protection device are applicable to the front side of the control signal system equipment, providing protection against the overvoltage arising from lightning to the control signal wire or misoperation. (option from standard IEC61643-21 and GB50343)

Main features

- ☆ High current capacity, low residual voltage.
- ☆ Introducing multilayer protection technology, strong protection ability, high reliable performance.
- ☆ Build-in earthing terminal, strong wiring ability, more reliable grounding.
- ☆ Modularization design, wiring terminal connection, convenient for installation and replacement.
- ☆ Protect two pairs of data line meanwhile, and space saving.

Main technical data

Type	LDY-C/X5	LDY-C/X12	LDY-C/X24	LDY-C/X48
Rated working voltage Un V	5	12	24	48
Max. continuous Voltage Uc V	8	18	36	75
Voltage protection level Up V	<50	<50	<80	<150
Part No.	085401	085402	085403	085404
Nominal discharge current In (8/20 μs) kA	5			
Wiring mode	Wiring terminal			
Transmission rate Vs(bit/s)	2M			
Insertion loss dB	≤0.3			
Enclosure material	enhanced flame retardant nylon (light gray, flame retardancy: V0)			
Installation method	35mm standard DIN rail installation			
Cross-sectional area	≥ 1 mm ² stranded/flexible			

Appearance and installation dimension

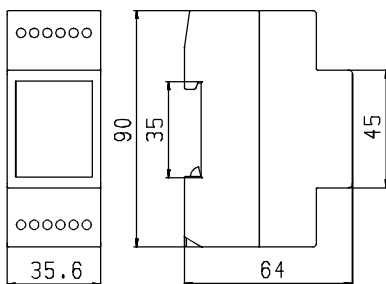

Schematic circuit diagram

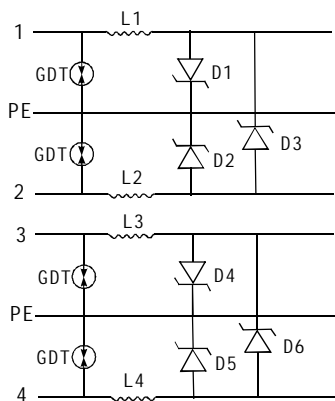

Installation instruction

1. The protector connected in serial between the signal channel and the protected device.
2. Connect the input terminal to the signal channel, and the output terminal to the protected device, reverse connection prohibited.
3. Connect the earthing wire of the protector to the equalizing ring of the lightning protection system
4. Invalid system: the earthing short circuit or open circuit